

# Estimation of waste mobile phones in the Philippines using neural networks

Galang. Mark Gino K.<sup>1</sup>, Ballesteros, Florencio Jr.<sup>1,2</sup>

<sup>1</sup>Environmental Engineering Graduate Program, University of the Philippines, Diliman, Quezon City 1101, Metro Manila, Philippines

<sup>2</sup>Corresponding author: fcballesteros@up.edu.ph

## Abstract.

Waste mobile phones are one of the subgroups of WEEE defined as discarded electronic products. This study estimated current and projected quantities of waste mobile phones in the Philippines using feed forward neural network. The neural network architecture used had three (3) layers: input layer, hidden layer and output layer. Seven (7) input factors were used during the learning phase of the network namely (i) population, (ii) literacy rate, (iii) mobile connections, (iv) mobile subscribers, (v) gross domestic product (GDP), (vi) GDP per capita and (vii) US dollar to peso exchange rate. The structure was designed with 5 hidden layers which consisted of; six (6) neurons for layer 1, five (5) neurons for layer 2, four (4) neurons for layer 3, three (3) neurons for layer 4 and two (2) neurons for layer 5. The neural network was designed to calculate first for the sales of mobile phones before estimating waste mobile phone generation. Visual Gene Developer 1.7 Software was used which showed an error of  $\pm 0.00001$ . Estimates and predicted values were found to be in good agreement with a calculated accuracy of 99%. This study can be used by policy makers as strategy, and as guideline and baseline data for establishing a proper management system for WEEE. The developed neural network performed better than the traditional linear extrapolation method for forecasting of data.

**Keywords:** WEEE, Neural Networks, generation rates

## 1. Introduction

Mobile phones have been one of the most popular among personal electronic devices in the Philippines since the country is known as the “texting capital of the world” as well as the “social media capital of the world” (GSMA Intelligence, 2015). Mobile devices are classified into two (2) categories: smartphones and feature phones. Smartphones are mobile devices that perform several functions of an integrated computer while feature phones are basically low-end mobile phones. Smartphones outperform feature phones due to their advanced operating systems, thus having higher penetration rates. This study dealt with a combination of the volume of waste mobile phones from both categories in the country. According to Sata (2013), the two (2) factors that affect consumers’ preferences in buying mobile phone are the price and features of the devices as indicated in an analysis of consumer behavior by the Euromonitor International

Journal and GSMA Intelligence (2015). Araujo *et al.* (2012) classified mobile phones under non-mature markets which means that their demand grows faster than the population. In this instance, bulk quantity of waste mobile phone is expected to rise due to the bustling transition of mobile phones in the market. Managing this particular type of WEEE is a pressing environmental challenge which may prompt government authorities to revise and update current policies and formulate clear guidelines. In the Philippines, an estimation of WEEE (Waste Electrical and Electronic Equipment) that is recycled, re-used, stored and disposed in landfills was conducted by Peralta *et al.* (2005) but mobile phones were excluded in the study. There are various estimation models available from the literature using input-output analysis, time series, regression models, market analysis models and mathematical equations. Each of these models differs from one another. The neural networks estimation method is a powerful tool for predicting values due to its non-parametric property. It is analogous to the operation of the human brain that involves neurons. Each neuron is connected to other neurons known as synapses which are activated depending on the input pulse. Synapses link information between connected neurons which are arranged in a layered fashion (Theodoridis, 2015).

## 2. Materials and method

### 2.1 Neural Networks Configurations

The different steps of the study is shown Figure 1. The neural networks training process was carried out using Visual Gene Developer 1.7 Software. During the training process, the software initially normalizes the input values to lessen the distance between magnitudes of the predictors. The next step is the initialization of the weight of the synapse to compute the value of every hidden layer. When the value of hidden layer is obtained, an activation function is used to transform the activation level of a unit (neuron) into an output signal. This study employed the following settings in the Visual Gene Developer 1.7 Software to obtain the target output.

#### 2.1.1. Neural network software

Visual Gene Developer 1.7 Software provided by McDonalds *et al.* (2011) was used to calculate the predicted output. It is an open-source software capable of the following features: construction of neural network structure, and provision of neural network map analysis,

prediction maps etc. It is of greater advantage over other software available online.

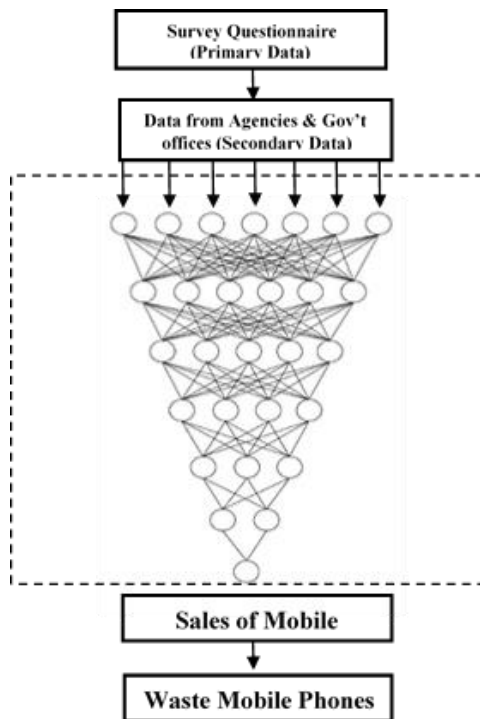

**Figure 1:** Procedure for the study

**Table 1.** Training settings in Visual Gene Developer 1.7 during data training process

Learning Rate	0.5
Momentum Coefficient	0.1
Transfer Function	Sigmoid
Maximum No. of Training Cycle	1,000,000,000
Target Error	0.00001
Analysis Update Interval (Cycles)	500

### 2.1.2. Input factors

In the absence of waste mobile phones data over the past years, initially, the neural network model was used to compute the sales of mobile phones before estimating the waste mobile phones in the country. To obtain the ideal input parameters, information from the GSMA Intelligence (2015) served as guidelines as to why the Philippines is a major innovation hub in mobile ecosystem. According to GSMA Intelligence (2015), the country is continuously successful in innovation due to (i) demography, (ii) economic credibility and (iii) mobile operators active in innovation. In line with this, the study employed factors that are related with the cited criteria. For instance, demography, population and literary rate were used as the input factors. For economic credibility, the inputs used were gross domestic product (GDP), average income per capita (GDP per capita) and US Dollar to Philippine Peso Exchange Rate. For the mobile operators, data for the number of mobile connections and unique mobile subscriber were used. Note that according to GSMA Intelligence (2015), mobile connections are the number of sim (Subscriber Identity Module) cards that an individual

possesses while unique subscribers are those individuals who subscribed to a mobile service and who can have multiple mobile connections. Historical sales data from 2010-2015 was obtained from Euromonitor International Journal to serve as reference data for the prediction output. Imported mobile phones were not covered by this study because data from government trade and statistics office were not available. Seven (7) input factors were used to generate a single output value which is the sales of mobile phones. Apart from the average lifespan of mobile phones of three (3) years, a survey with 150 respondents was conducted to evaluate the disposal/replacement behaviors of consumers. The survey consisted of questions about the period on how the consumer used their mobile phone before it is disposed/replaced. Results indicated that consumers dispose/replace their mobile phones in less than one year (<1 year), between 1-2 years and 2 years onwards. The result of the estimation shall be the values for the volume of waste mobile phones generated.

### 2.2. Secondary data collection

Data from different agencies and government offices were obtained and served as secondary data. Population data was taken from Philippine Statistic Authority (PSA), literacy rate was taken from United Nations Education, Scientific and Cultural Organization (UNESCO), mobile connections and unique mobile subscribers were taken from National Telecommunications Commission (NTC), Gross Domestic Product, Average income and US Dollar to Philippine Peso exchange rate were taken from Trading Economics and Central Bank of the Philippines and the sales of mobile phones from 2010 to 2015 was taken from Euromonitor Journal. Table 2 present the data collected from these agencies.

### 2.3. Estimation of waste mobile phones

Data of waste mobile phones for less than 1 year, between 1 year to 2 years and 2 years and above were derived from the results of survey. The model and equation used in estimating waste mobile phones are shown below (See Figure 2 and Equation 1):

$$\text{Waste Mobile Phone for a specific year } (j) = (x \text{ at } j) + (y \text{ at } j_1) + (z \text{ at } j_2) \quad \text{Equation. 1}$$

Where:

- $x$  = waste mobile phone with less than 1 year
- $y$  = waste mobile phone between 1 year to 2 years
- $z$  = waste mobile phone from 2 years and above
- $j$  = specific year
- $j_1$  = one (1) year before the specific year
- $j_2$  = two (2) years before the specific year

## 3. Results and discussion

Results of the survey showed that the average number of mobile phones owned per individual is 1.233. The average number of sim cards used per mobile phone is 2.00. Majority of the respondents own smartphones while some respondents own both smartphones and feature phones. Nine (9) % of the total respondents disposed and/or replaced their mobile phones after one (1) year of usage; 54% disposed and/or replaced their mobile phones between one (1) to two (2) years of usage and the

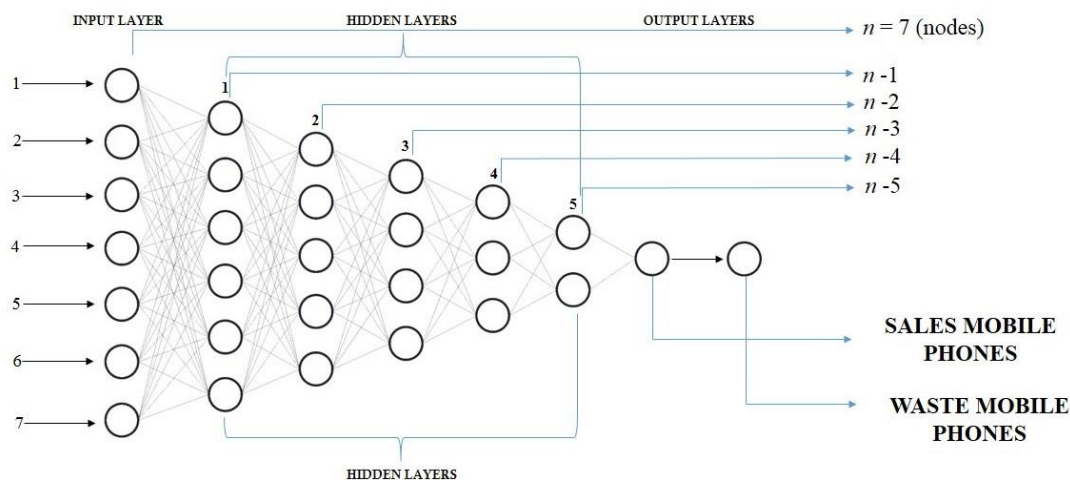

**Figure 2.** Structure of the neural network model

**Table 2.** Historical data from different agencies and government offices

DEMOGRAPHY			MOBILE OPERATORS DATA		ECONOMIC CREDIBILITY			
YEAR	POPULATION	LITERACY RATE MF (%)	MOBILE CONNECTIONS	UNIQUE MOBILE USERS	GDP (Billion Peso)	AVE. INCOME (GDP per CAPITA)	DOLLAR to PESO Exchange Rate	SALES OF MOBILE PHONES
2010	94,013,200	95.6571	83,150,238	41,575,119	9,003,960,000,000	95,773	45.11	13,867,200
2011	95,803,620	95.7857	94,189,275	47,094,638	9,705,770,000,000	101,309	43.31	14,501,600
2012	97,594,040	95.9143	101,978,345	50,989,173	10,565,950,000,000	108,264	42.23	17,550,100
2013	99,384,460	96.0429	102,823,569	51,411,785	11,496,230,000,000	115,674	42.25	19,085,600
2014	101,174,860	96.1714	116,835,776	58,417,888	12,633,390,000,000	124,867	44.39	21,296,300
2015	102,965,300	96.5	130,848,296	65,424,148	13,518,050,000,000	131,287	45.5	23,618,300

remaining 37% disposed and/or replaced their mobile phones when it reached 2 years and above. The 9% of the respondents that disposed and/or replaced their cellphones after one (1) year were mostly users of feature phones. The analysis showed that the disposal and/or replacement cycle for feature phones is fast because this particular category of mobile phone is inexpensive. Advanced features and better specifications were among the influencing factors to customer's buying preferences. It is worth noting that 95% of the total respondents have no knowledge on proper disposal of mobile phones. During the training cycle, results showed that at  $1.542 \times 10^6$  iterations with the sum squared error (SSE) at 0.00001, the obtained generation estimates for the sales of mobile phones are 24,638,606 units for 2016; 24,846,842 for 2017; 24,888,616 units for 2018; 24,903,568 units for 2019; 24,910,788 units for 2020 and 24,914,970 units for 2021. Using equation 1, the waste mobile phones are 22,850,988 for 2016; 24,279,834 units for 2017; 24,773,554 units for 2018; 24,874,505 units for 2019; 24,898,686 units for 2020 and 24,908,493 units for 2021.

#### 4. Conclusion

Demand for mobile phones will continuously increase. Since this type of WEEE is increasing in volume, it poses threats not only to the environment but also to human health when not properly managed. Realizing this threat, this study attempted to do the primary step to address it by estimating the volume of waste mobile phones in the country. The study was able to estimate data on sales of mobile phones and subsequently the waste mobile phones

in the country from 2010-2021 with a calculated accuracy of 99%.

#### References

- Alter H. (2000). Environmentally sound management of the recycling of hazardous wastes in the context of the Basel Convention. *Resources, Conservation and Recycling* 29 (2000) 111-129.
- Almaghribi G., Putraa S., Triyono R. (2015). Neural network method for instrumentation and control cost estimation of the EPC companies bidding proposal. *Procedia Manufacturing* 4 (2015) 98 - 106.
- Antonio R., Kong C., Ong R., Sapitan J. (2014). On Estimation of Electronic Waste from Cellular Phones (CPw) in the Philippines. University of the Philippines, Diliman, Quezon City
- Araújo M., Magrini A., Mahler C., Bilitewski B. (2012). A model for estimation of potential generation of waste electrical and electronic equipment in Brazil. *Waste Management* 32 (2012) 335-342.
- Basel Convention (2010). Environmentally sound management of used electrical and electronic equipment (e-waste) in Asia-Pacific. Available at [www.basel.int](http://www.basel.int)
- Blake J., Francino P., Catot J., Sole I., (1995). A Comparative Study for Forecasting using Neural Networks vs Genetically Identified Box & Jenkins Models. *Neural Comput & Applic* (1995)3:139-148.
- Brian Carisma (2009). Drivers of and barriers to E-waste management in the Philippines. IIIIEE Theses 2009:03.
- Deloitte Access Economics (2013). Mobile Nation: The economic and social impacts of mobile technology.

- Dwivedy M., Mittal R.K., (2010). Estimation of future outflows of e-waste in India. *Waste Management* 30 (2010) 483–491.
- Euromonitor International Journal (2015). *Mobile Phones in the Philippines*.
- European Commission (2002). Frequently asked questions on Directive 2002/95/EC on the restriction of the use of certain hazardous substances in electrical and electronic equipment (RoHS) and Directive 2002/96/EC on waste electrical and electronic equipment (WEEE). Available at [http://europa.eu.int/comm/environment/waste/pdf/faq\\_weee.pdf](http://europa.eu.int/comm/environment/waste/pdf/faq_weee.pdf)
- EU Directive 2002/96/EC of the European Parliament and of the Council of 27 January 2003 on waste electrical and electronic equipment (WEEE). Official Journal of the European Union L37:24–3813/02/2003. Available at [http://europa.eu.int/eurlex/pri/en/oj/dat/2003/l\\_037/l\\_03720030213en00240038.pdf](http://europa.eu.int/eurlex/pri/en/oj/dat/2003/l_037/l_03720030213en00240038.pdf)
- GSMA Intelligence (2014). Country overview: Philippines Growth through innovation.
- GSMA Intelligence (2014). The Mobile Economy Asia Pacific 2015.
- Gutiérrez E., Adenso-Díaz B., Lozano S., González-Torre P. (2010). A competing risks approach for time estimation of household WEEE disposal. *Waste Management* 30 (2010) 1643–1652.
- Fujimoria T., Takigami H., Agusa T., Eguchi A., Bekkia K., Yoshida A., Terazono A., Ballesteros Jr., F., (2012). Impact of metals in surface matrices from formal and informal electronic-waste recycling around Metro Manila, the Philippines, and intra-Asian comparison. *Journal of Hazardous Materials* 221–222 (2012) 139–146.
- Habuer, Nakatani J., Moriguchi Y. (2014). Time-series product and substance flow analyses of end-of-life electrical and electronic equipment in China. *Waste Management* 34 (2014) 489–497.
- Ingrams A., (2015). Mobile phones, smartphones, and the transformation of civic behavior through mobile information and connectivity. *Government Information Quarterly* 32 (2015) 506–515.
- Jones E., Ph.D., (2004). Visual Numeric, Inc.; *Introduction to Neural Networks*.
- Koprinkova P., Petrova M. (1999). Data-scaling problems in neural-network training. *Engineering Applications of Artificial Intelligence* 12 (1999) 281–296.
- Kuehr R., (2012). *Global e-waste initiatives*. United Nations University.
- Li B., Yang J., Lu B., Song X., (2014). Estimation of Retired Mobile Phones Generation in China: A comparative study on methodology. *Waste Management* 35 (2015) 247–254.
- Mmereki D., Li B., Wang L., (2012). Estimation of waste electronic and electrical equipment arising in Botswana - A case study of Gaborone City. *International Journal of Environmental Science* Vol. 3, No. 1.
- Molaie M., Falahian R., Gharibzadeh S., Jafari S., Spratt J., (2014). Artificial Neural Networks: powerful tools for modeling chaotic behavior in the nervous system. *Frontiers in Computational Neuroscience*, Vol.8, Article 40.
- Oancea B., Ciucu S., (2005). Time Series Forecasting using Neural Networks. Professor, PhD, “Nicolae Titulescu” University of Bucharest.
- Ogunseitani O., (2013). *The Basel Convention and e-waste: translation of scientific uncertainty to protective policy*. Department of Population Health and Disease Prevention, Program in Public Health, University of California, Irvine, CA 92697, USA.
- Park H., Baek S. (2008). An empirical validation of a neural network model for software effort estimation. *Expert Systems with Applications* 35 (2008) 929–937.
- Peralta G., Fontanos P., (2006). E-waste issues and measures in the Philippines. *J Mater Cycles Waste Manag* (2006) 8:34–39.
- Petridis N., Stiakakis E., Petridis K., Dey P. (2015). Estimation of computer waste quantities using forecasting techniques. *Journal of Cleaner Production* 112 (2016) 3072–3085
- Polák M., Drápalová L., (2012). Estimation of end of life mobile phones generation: The case study of the Czech Republic. *Waste Management* 32 (2012) 1583–1591.
- Rahmania M., Nabizadeh M., Yaghmaeiana K., Mahvia A., Yunesian M., (2014). Estimation of waste from computers and mobile phones in Iran. *Resources, Conservation and Recycling* 87 (2014) 21–29.
- Robinson B., (2009). E-waste: An assessment of global production and environmental impacts. *Science of the Total Environment* 408 (2009) 183–191.
- Sata M. (2013). Factors Affecting Consumer Buying Behavior of Mobile Phone Devices. *Mediterranean Journal of Social Sciences* Vol. 4 No. 12.
- Scharnhorst W., (2008): Life Cycle Assessment in the Telecommunication Industry: A Review. *Int. J LCA* 13 (1) 75–86.
- Shanker M., Hu M.Y., Hung M.S., (1996). Effect of Data Standardization on Neural Network Training. *Omega, Int. J. Mgmt Sci.* Vol. 24, No. 4, pp. 385–397.
- Sohl J., Venkatachalam A.R., (1995). A neural network approach to forecasting model selection. *Information & Management* 29 (1995) 297–303.
- Steubing B., Schluep H., Silva U., Ludwig C. (2010). Assessing computer waste generation in Chile using Material Flow Analysis. *Waste Management* 30 (2010) 473–482.
- Terazono A., Murakami S., Abe N., Inanc N., Moriguchi Y., Sakai S., Kojima M., Yoshida A., Li J., Yang J., Wong M., Jain A., Kim I., Peralta G., Lin C., Mungcharoen T., Williams C., (2006). Current status and research on E-waste issues in Asia. *J Mater Cycles Waste Manag* (2006) 8:1–12.
- Thavalingam V., Karunasena G., (2016). Mobile phone waste management in developing countries: A case of Sri Lanka. *Resources, Conservation and Recycling* 109 (2016) 34–43.
- Theodoridis S., 2015. *Chapter 18 - Neural Networks and Deep Learning. Machine Learning, A bayesian and Optimization Perspective 2015*, Pages 875–936.
- Thiesing F., Vornberger O., (1997). Sales Forecasting using Neural Network. Proceedings ICNN'97, Houston, Texas, 9–12 June 1997, Vol. 4, pp. 2125–2128, IEEE, 1997.
- The Philippines Government (2000). *Ecological Solid Waste Management Act of 2000, RA 9003*. Available at <http://www.emb.gov.ph>
- The Philippines Government (1990) *Toxic Substances and Hazardous and Nuclear Wastes Control Act of 1990, RA6969*. Available at <http://www.emb.gov.ph>
- Wanga F., Huisman J., Stevels A., Baldé C. (2013). Enhancing e-waste estimates: Improving data quality by multivariate Input–Output Analysis. *Waste Management* 33 (2013) 2397–24